

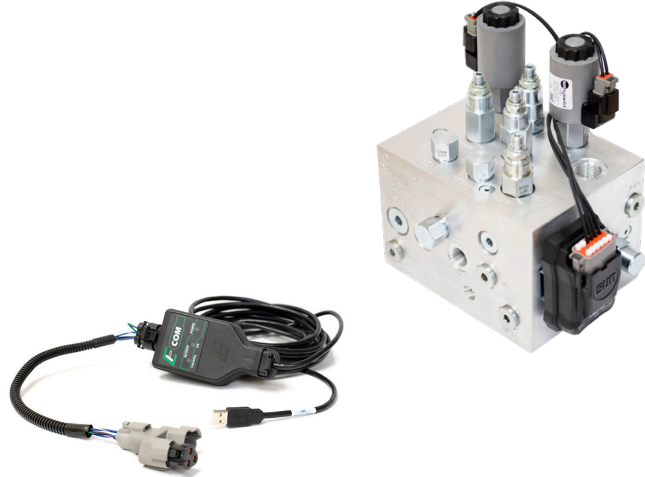

## XMD Configuration Software

Get more from your XMD Mobile Valve Driver with new closed-loop, PID & fan drive control capabilities





# Simplifying advanced hydraulic control

The full capabilities of the Sun Hydraulics XMD mobile drivers are at your fingertips with the new CANpoint XMD Configuration Software. Now the world's smallest, most powerful driver can be configured quickly and easily over CAN bus using a PC, our CANpoint software and an ECOM dongle.

The launch of this new software allows XMD users to implement open-loop, closed-loop (PID) and hydraulic fan drive control using pre-programmed modes (available for XMD-02).

In addition, CANpoint delivers additional critical features for setting up your application:

- Live graphing with data logging
- Live CAN data traffic view
- Multiple input types (voltage, current, PWM, frequency, resistive, digital)
- Scalable input values
- Multi-point calibration
- Simplified output settings
- Password-protected systems settings

CANpoint simplifies advanced hydraulic control using a clear, simple software interface that allows for point-and-click output shaping with excellent resolution and predictable results. And it requires no programming to take you from connecting to configuring to completing your application setup.

**Expand capability.**  
**Eliminate complexity.**  
**Exercise creativity.**

In the Dashboard, you can view inputs and output in real time and store results for post-data analysis. At a glance, you can see everything you need to evaluate your application and optimize your results.

Expand your XMD capabilities, eliminate configuration complexity and exercise your creativity in your electro-hydraulic control applications with Sun's new CANpoint XMD Configuration Software.

## CANpoint dashboard

Get the overview on your project in the CANpoint Dashboard.

- Real-time plotting
- Data logging for post-analysis
- Real-time view of inputs and outputs
- Data in raw and scaled values
- Diagnostic indicators with descriptions

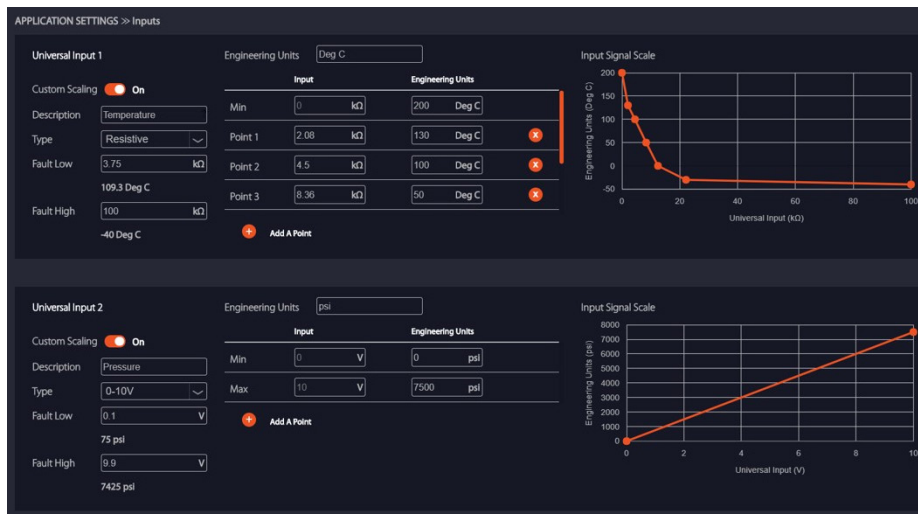
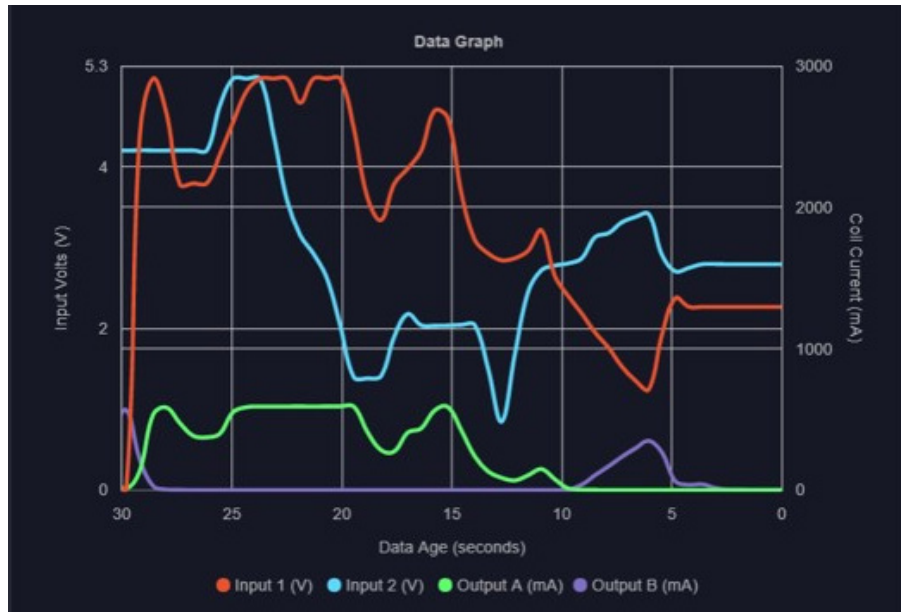

## Flexible input options

The XMD driver accommodates multiple input types, and CANpoint helps you make the most of them.

- Voltage
- Current
- PWM
- Frequency
- Resistive
- Digital

Scaled input values allow for user-defined engineering units and descriptions. CANpoint offers multi-point calibration. Inverse curve management controls resistive temperature inputs.

## Robust J1939 CAN bus settings

CAN bus settings in CANpoint offer user flexibility, meets necessary bus requirements and adds an additional third CAN input for the XMD driver.

User-managed settings include:

- Add gain and offset values to the unit of measure for required scaling for standard J1939 messages
- Define CAN value scaled units and transmission rate
- Independently define transmit PGN values
- Create unique descriptions for easy reference

CANpoint also uses transmitted data from displays and controllers through the XMD for system diagnostics.

## Output settings

CANpoint provides a simplified output menu for most common solutions and end-use cases:

- PWM frequency
- Output mode
- Ramp settings

The advanced functionality option provides more control for the advanced user:

- Output current regulation PID settings
- Robust fault detection that includes user-defined fault status modes

# I/O configuration modes: open-loop, closed-loop PID, and hydraulic fan drive control

CANpoint includes four user-selectable I/O configuration modes for common applications that require no programming from the user. Just choose

your configuration, apply your settings, and push the configuration to the XMD-02 driver via the CAN dongle.

## Closed-loop PID mode

The closed-loop PID mode provides additional functionality based on the two PID loops. See PID loop diagram below (Figure 1).

- PID loops enable the control of output A and output B independently
- Each PID loop provides command and feedback
- Applicable for position, pressure and flow control

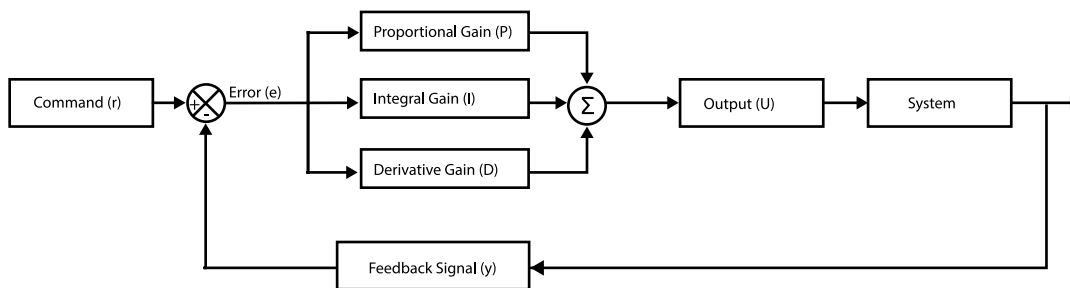

Figure 1  
Closed-loop PID mode

## Open-loop mode

In addition to the customizable input/output settings, the CANpoint open-loop mode provides the following functions:

- User-defined input variables for each output
- Additional points available for custom output shaping
- Thermostat on/off feature for high- and low-pressure and flow-control applications

## Hydraulic fan drive control modes

CANpoint controls your unidirectional or bidirectional hydraulic fan drives using up to five configurable inputs not limited to temperature. Inputs available include two universal inputs and three CAN values. See reversing mode at right (Figure 2).

Features include:

- Start-up delay
- Ignition switch
- Minimum engine RPM
- Reverse toggle
- Auto-reverse
- Minimum fan speed protection
- Minimum pressure protection

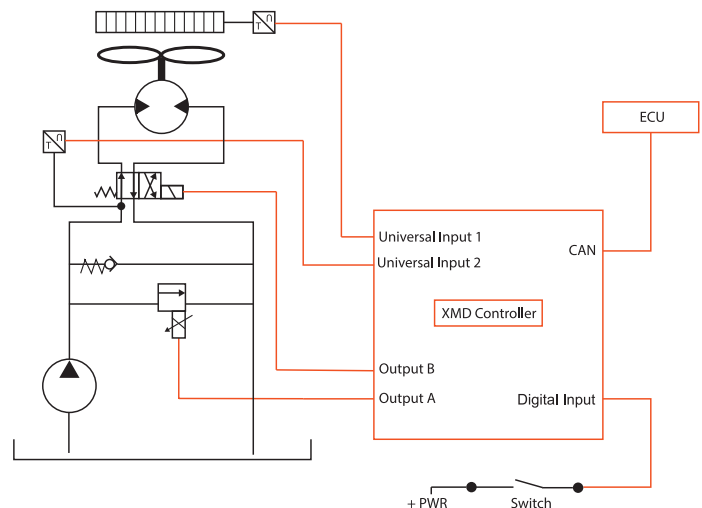

Figure 2  
Hydraulic fan drive control - reversing mode



1500 West University Parkway  
Sarasota, Florida 34243, USA  
+1 941 362 1200

February 2020